

BLA21-28U-A02 / AB2 Technical Specification

BLA21-28U-A02 / AB2 Technical Specification

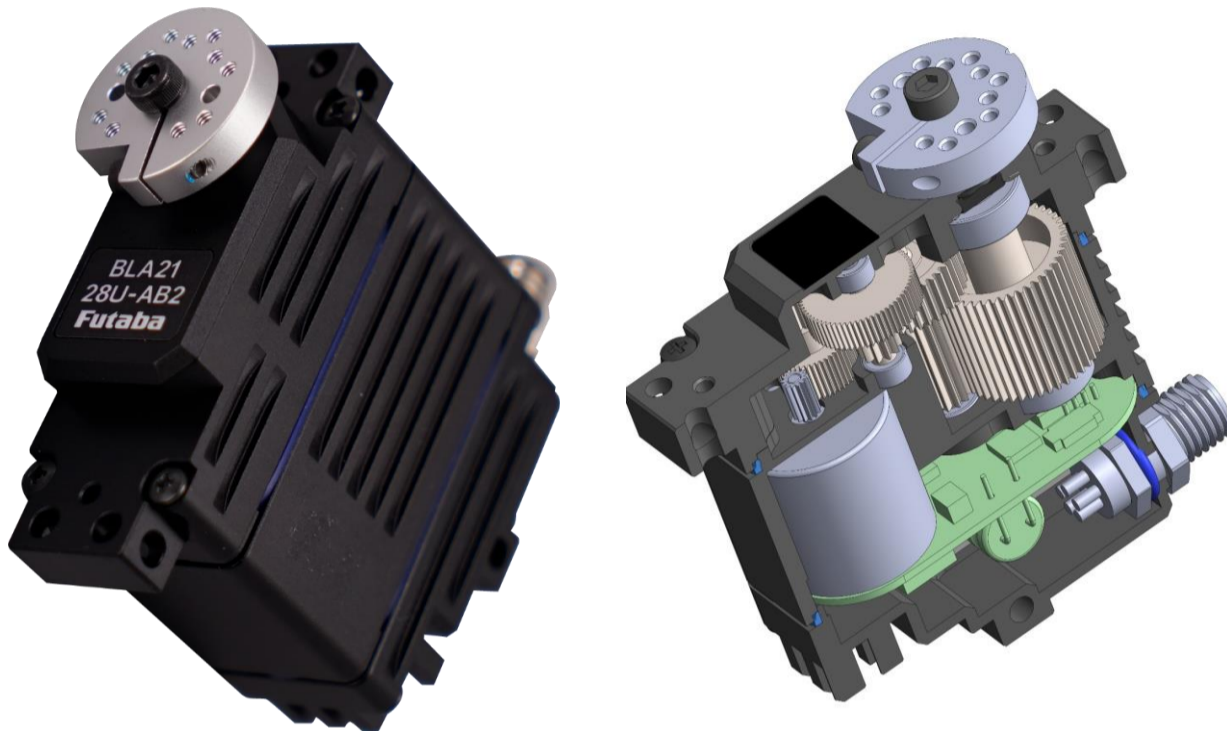

- BLA21-28U-A02 : Supports UAVCAN v0 signals.
Case shielded line and Battery line(-) are separated.
No PWM
- BLA21-28U-AB2 : Supports UAVCAN v0 and PWM signals.
Case shielded line and Battery line(-) are common.
No Case shield

BLA21-28U-A02 / AB2 Technical Specification**Basic specifications (BLA21-28U-A02 and AB2)**

Item		Specification				Remark
1	Rated Voltage	24.0 ~ 28.0V				DC power supply.
2	Operating Voltage	20.0 ~ 32.0V				DC power supply.
3	Standby Current	≤ 42mA				at 28.0V
4	Starting Current *	Design value	≤ 5A			The maximum peak current may reach 5A for a short moment before the over current protection is activated.
		Over current protection	BLA21-28U-A02:	3.2A (TBC)		For the self-protection purpose the peak current can be limited in the range from 1.6A to 3.2A / 2.4A on the CANBUS line and on the program tool additionally provided by Futaba. 3.2A / 2.4A is the default setting and corresponds to the maximum torque at 28.0V (see No.6).
		BLA21-28U-AB2:	2.4A (TBC)			
5	Consumption Current *	LL	Me	UL	unit	at 28.0V , No-Load LL : Low Limit Me : Medium Value UL : Upper Limit
		30	80	145	mA	
6	Max. Torque *	34.0	46.0	58.0	kgf·cm	at 28.0V
		3.33	4.51	5.69	N·m	
		472	639	805	ozf·in	
		44.0			kgf·cm	at 24.0V
7	Rated Torque *	15.0			kgf·cm	at 28.0V
		1.47			N·m	
		208			ozf·in	
		13.9			kgf·cm	at 24.0V
8	No Load Speed * (Angle control mode)	LL	Me	UL	unit	at 28.0V
		0.04	0.07	0.10	s/60°	
		600	857	1500	°/s	
		100	143	250	rpm	
	0.08			s/60°	at 24.0V	
	No Load Speed * (Speed control mode)	LL	Me	UL	unit	at 28.0V
100		143	250	rpm		
9	Travel Angle * (Angle control) + :CW - :CCW	Range	+179.9° ~ -180.0° (Absolute)			See also No.25 and No.27 for other operating modes in addition to the absolute angle control.
		Accuracy	±3.0° (Standard)			at 28.0V, No-Load, positioned at ±60°
			±1.5° (Measured)			
10	BackLash *	≤ 0.5°				—
11	Temperature Range	Operating	-40~+70°C (-40~158°F)			The operating noise level may increase at a low temperature range.
		Storage	-40~+80°C (-40~176°F)			—
		Over heat protection	+80°C (176°F)			The default temperature to activate the self-protection function "Torque OFF" in order to prevent overheat. The temperature can be set from 20°C ton 80°C on the CANBUS line and on the program tool additionally provided by Futaba.

BLA21-28U-A02 / AB2 Technical Specification

Mechanical specifications (BLA21-28U-A02 and AB2)

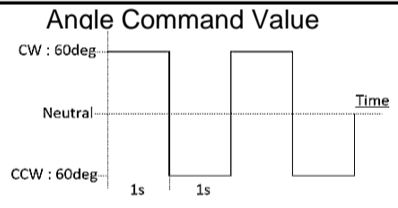
Item	Specification	Remark
12	Outer Dimension 48.0x 21.0 x 51.0mm (1.89 x 0.83 x 2.01 in)	See below Outer Dimension
13	Weight 127g	with Horn and screws without cables
14	International Protection Code IP67	Waterproof and dustproof
15	Case Material Aluminum	Surface : Anodized Salt Water Resistance, EMI Case Shielding
16	Gear Set Material Steel	Surface : Hardening treatment
17	Gear bearing 8 ball bearing	—
18	Output Shaft Serration S6L	Size: ϕ 6mm, 25 teeth, Long type
19	Radial load 100N (for reference use only)	Load position : See below Outer Dimension
20	Position Sensor Magnetic Encoder	—
21	Motor Type Brushless DC Motor	
22	MTTF *	<p>Operating time > 1,000h (TBC) (Inquire for the test report)</p> <p><u>Operating Condition</u></p> <ul style="list-style-type: none"> at 28.0V $\pm 60^\circ$, 0.5Hz sweep <p><u>Test Condition</u></p> <ul style="list-style-type: none"> Load : Rated Torque (Powder Brake) 
		<p>Operating time \geq 1,000h (TBC) (Inquire for the test report)</p> <p><u>Operating Condition</u></p> <ul style="list-style-type: none"> at 28.0V $\pm 60^\circ$, 0.5Hz sweep No-Load <p><u>Test Condition (sine wave)</u></p> <ul style="list-style-type: none"> Frequency : 10 to 500Hz sweep 1oct/min amplitude limit 2mm Acceleration : 300m/s² Vibration axis : X,Y,Z
23	Vibration Resistance *	<p>Equivalent to MIL-STD-810H Method 514.8 (Annex E , Minimum Integrity) 1h per axis (Applicable model is BLA21-28U-AB2)</p> <p><u>Operating Condition</u></p> <ul style="list-style-type: none"> at 28.0V $\pm 60^\circ$, 0.5Hz sweep No-Load <p><u>Test Condition (Random wave)</u></p> <ul style="list-style-type: none"> Refer to MIL-STD-810H Method 514.8 Company internal test

BLA21-28U-A02 / AB2 Technical Specification

Outer Dimension (BLA21-28U-A02 and AB2)

(unit : mm)

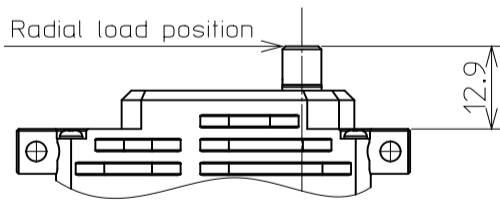
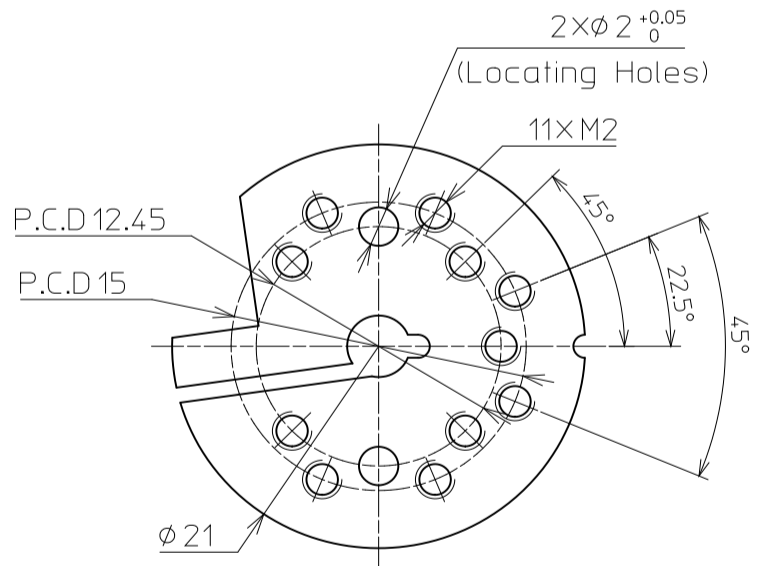
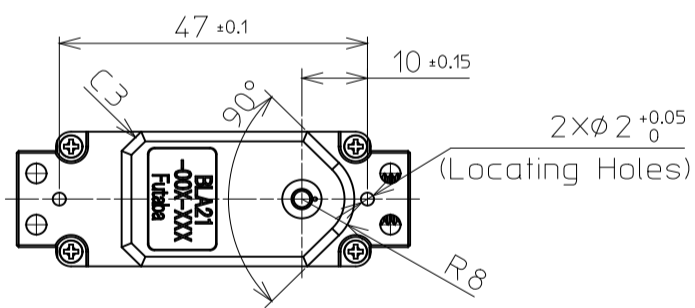
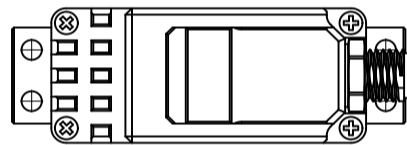
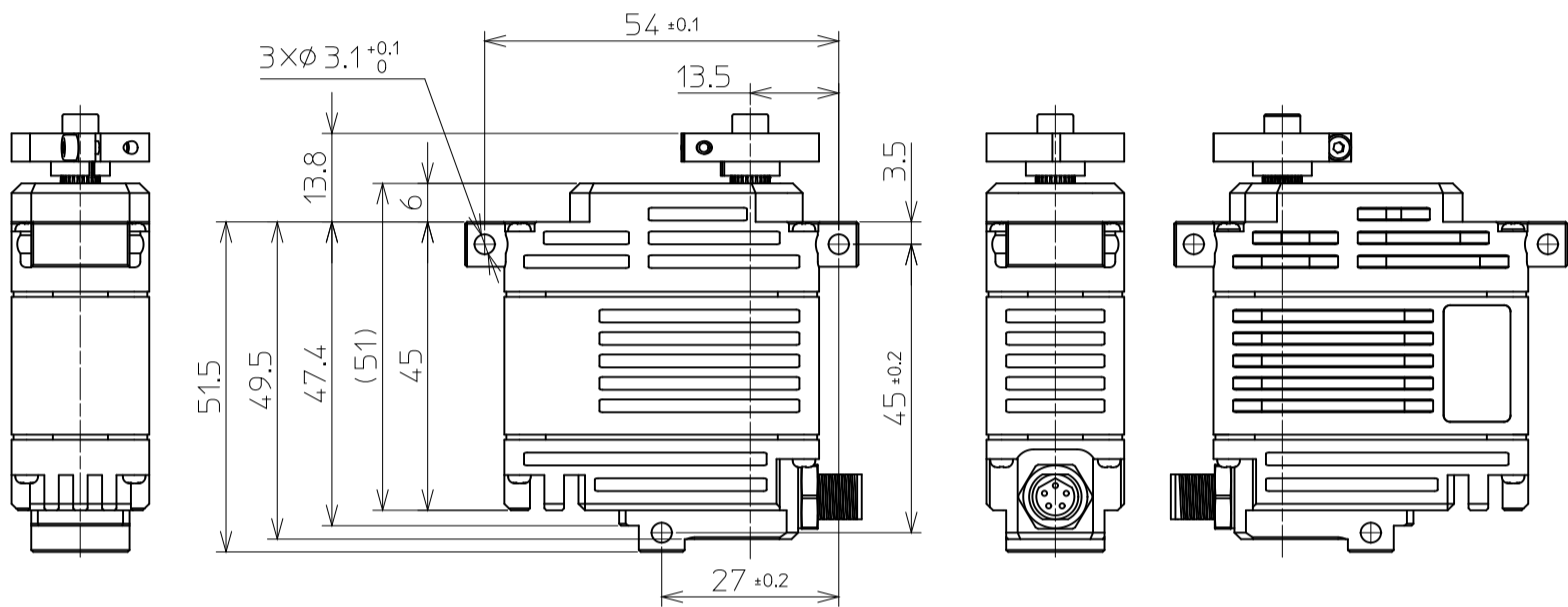
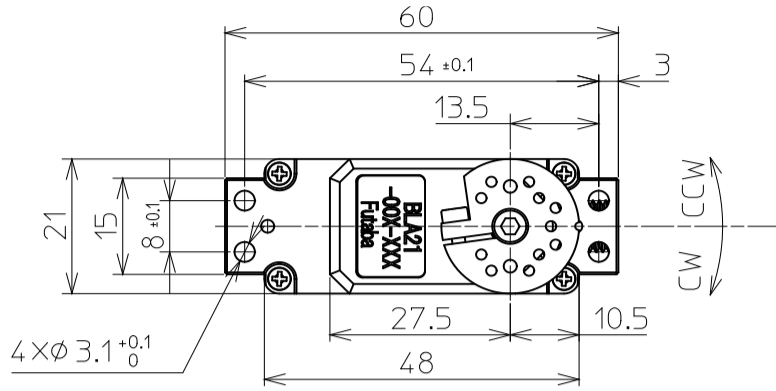

Without Servo Horn

Servo Horn

OUTPUT SHAFT

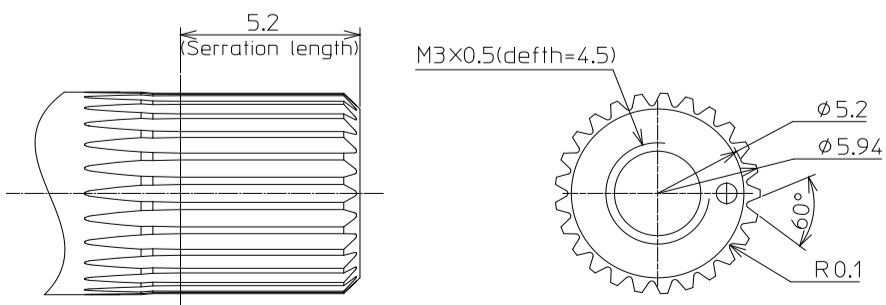

Sarretion Size

Standard Diameter : $\Phi 6$
Angle : 60°
Tooth : 25

BLA21-28U-A02 / AB2 Technical Specification

Specifications for CAN BUS signals (BLA21-28U-A02 and AB2)

Item		Specification		Remark	
24	Communication Interface	CAN BUS		Protocol	UAVCAN V0
				Baud Rate	1Mbps
				Sample Point	87.5%
				Node ID	1~127
				(Please ask us for more information)	
25	Operating mode (CANBUS) + :CW - :CCW (Turn direction reversible)	Angle control (Absolute)	TravelAngle: +179.9° ~ -180.0°	Absolute meaning the position in this range is absolute. The servo can acknowledge this range even after switching off and the position command within this range is identified uniquely. For the accuracy in this operating mode see No.9.	
		Angle control (multi-turn)	TravelAngle: +36,000,000.0° ~ -36,000,000.0°	The servo can accept > 360° position commands within the range. (e.g. Command +3600° means to come back to the start position after rotating 10 times clockwise.) The servo will lose the multi turn information once switched off and the position will be identified within the absolute range of 360°.	
		Speed control	Max Speed: +300rpm ~ -300rpm	This operating mode is used for applications where servo rotates continuously. The speed can range within ± 300 rpm and can be set on the CANBUS line and on the program tool additionally provided by Futaba. See also No.8 for the speed aberration.	
		Torque control	Max Torque: +100% ~ -100%	This operating mode is used for applications where servo is supposed to output a constant torque. The torque can range within ± 100% and can be set on the CANBUS line and on the program tool additionally provided by Futaba. 100% means 3.2A (A02) / 2.4A (AB2) and indicates the maximum torque at 28.0V (see No.6).	

Specifications for PWM signals (Only BLA21-28U-AB2)

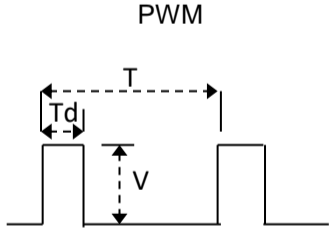
Item		Specification		Remark									
26	Communication Interface			Signal Voltage:V	HIGH : min. 2.0V max. 5.0V								
					LOW : min. 0.0V max. 0.45V								
				Frame Rate:T	14.25ms								
				CW / Center / CCW:Td	Default 2120 / 1520 / 920μs								
27	Operating Mode (PWM) + :CW - :CCW (Turn direction reversible)	Angle control (Absolute)	<table border="0"> <tr> <td>Default</td> <td>Max.</td> </tr> <tr> <td>+60.0° (2120μs)</td> <td>+180.0°</td> </tr> <tr> <td>Neutral 0° (1520μs)</td> <td>Neutral 0°</td> </tr> <tr> <td>-60.0° (920μs)</td> <td>-180.0°</td> </tr> </table>	Default	Max.	+60.0° (2120μs)	+180.0°	Neutral 0° (1520μs)	Neutral 0°	-60.0° (920μs)	-180.0°	The travel-ends are ±60° (default) lead by the pulse 1520±600μs where the input-width is 600μs centering the neutral of 1520μs. The travel-ends can be set from ±60° to ±180° on the CANBUS line and on the program tool additionally provided by Futaba. Also both the neutral 1520μs and input-width 600μs can be set within the range of 100 to 10,000μs and 10 to 10,000μs respectively.	
		Default	Max.										
		+60.0° (2120μs)	+180.0°										
		Neutral 0° (1520μs)	Neutral 0°										
-60.0° (920μs)	-180.0°												
Angle control (Extended)	<table border="0"> <tr> <td>Default</td> <td>Max.</td> </tr> <tr> <td>+360.0° (2120μs)</td> <td>+360.0°</td> </tr> <tr> <td>Neutral 0° (1520μs)</td> <td>Neutral 0°</td> </tr> <tr> <td>-360.0° (920μs)</td> <td>-360.0°</td> </tr> </table>	Default	Max.	+360.0° (2120μs)	+360.0°	Neutral 0° (1520μs)	Neutral 0°	-360.0° (920μs)	-360.0°	The travel-ends can be extended to ±360° exceeding the absolute range of ±180°. Once the servo is switched off, the position in the extended range (±360°> position > ±180°) will be identified within the absolute range. (e.g. the end position CW 270° will be regarded as CCW90°)			
Default	Max.												
+360.0° (2120μs)	+360.0°												
Neutral 0° (1520μs)	Neutral 0°												
-360.0° (920μs)	-360.0°												
Speed control	Max Speed: +600rpm (2120μs) 0rpm (1520μs) -600rpm (920μs)	This operating mode is used for applications where servo rotates continuously. The speed can range within ± 600 rpm and can be set on the CANBUS line and on the program tool additionally provided by Futaba. See also No.8 for the speed aberration.											
Torque control	-	Not available for PWM signals.											

BLA21-28U-A02 / AB2 Technical Specification

Connector specifications (Only BLA21-28U-A02)

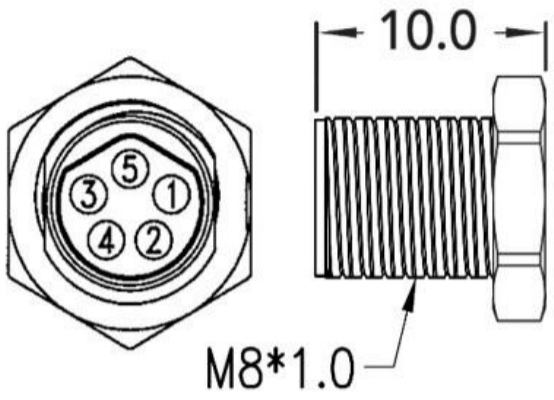
Item		Specification			Remark	
28	Cable	Shielded Cable (Detachable)			Cable Length : 15.75 inch (400mm)	
29	Connector	Manufacture	ODS Electronics Co., Ltd.			
		Type	MMEPM05MCC-SHS7001			
		Mating	MAEAF05FCC-SRC7000 etc.			
30	Pin Assignment	Pin No.	Assignment	Cable Color		
		①	Battery (+)	Brown		
		②	Battery (-)	White		
		③	CAN-H	Blue		
		④	CAN-L	Black		
		⑤	Case Shield Line	Drain		

Connector specifications (Only BLA21-28U-AB2)

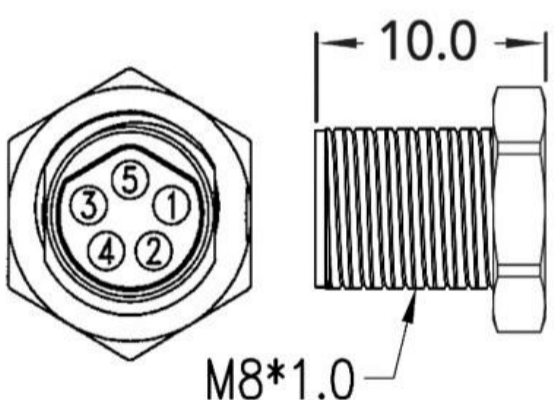
Item		Specification			Remark	
31	Cable	Shielded Cable (Detachable)			Cable Length : 15.75 inch (400mm)	
32	Connector	Manufacture	ODS Electronics Co., Ltd.			
		Type	MMEPM05MCC-SHS7001			
		Mating	MAEAF05FCC-SRC7000 etc.			
33	Pin Assignment	Pin No.	Assignment	Cable Color		
		①	Battery (+)	Brown		
		②	PWM	White		
		③	CAN-H	Blue		
		④	CAN-L	Black		
		⑤	Battery (-) and Case Shield Line	Drain		

* At 23±5°C (Initial Performance Data)

All Specifications are subject to change without prior notice.

BLA21-28U-A02 / AB2 Technical Specification

Model name system

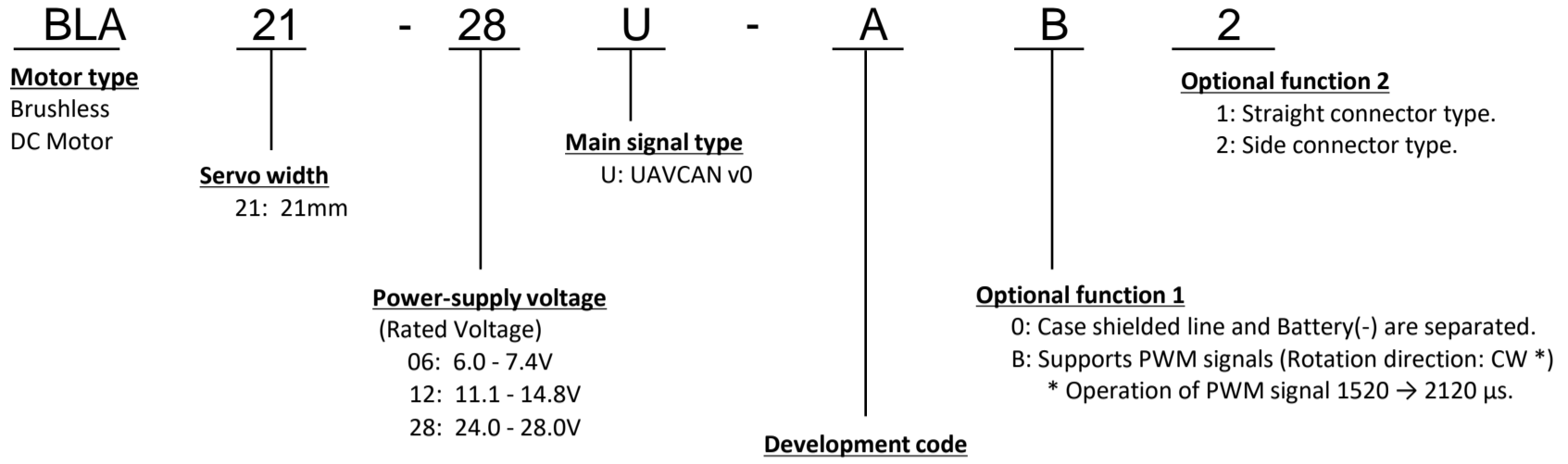

■ **Caution**

- This product **SHOULD NOT** be used for the devices that is directly related to human life.
- Keep the servo away from an object which produces a strong magnetic field.
There is a possibility of malfunction if the servo is affected by a strong magnetic field.