

BLA1HH41 Technical Specification

Update Number

200911-03

Item		Specification				Remark	
1	Communication Interface	PWM				Signal Voltage:V	HIGH : min. 2.0V max. Vcc
						Frame Rate:T	3.0~30ms
						CW/Center/CCW:Td	920/1520/2120μs (Resolution recommends less than 1μs.)
		S.BUS				Futaba Serial Protocol (Please ask us for more information.)	
2	International Protection Code	IP64				Waterproof and Dustproof	
3	Rated Voltage	11.1~14.8V DC				-	
4	Operating Voltage	9.0~16.8V DC				-	
5	Standby Current	≤ 55mA				at 11.1~14.8V	
6	Starting Current	5.5A				at 14.8V	
7	Consumption Current*	LL	Me	UL	unit	at 14.8V (at 12.0V) , No-Load	
		140(110)	275(220)	410(330)	mA	LL : Low Limit Me : Medium Value UL : Upper Limit	
8	Max. Torque*	LL	Me	UL	unit	at 14.8V (at 12.0V)	
		31.4(26.5)	44.0(37.0)	56.6(47.5)	kgf-cm		
		3.08(2.60)	4.32(3.63)	5.55(4.66)	N-m		
		436.1(368.0)	611.0(513.8)	786.0(659.7)	ozf-in		
9	Rated Torque*	LL	Me	UL	unit	at 14.8V	
		6.3	8.8	11.3	kgf-cm	20% of Max. Torque	
		0.62	0.86	1.11	N-m		
		87.2	122.2	157.2	ozf-in		
10	No Load Speed*	LL	Me	UL	unit	at 14.8V (at 12.0V)	
		0.07(0.09)	0.1(0.12)	0.13(0.15)	sec/60°		
		461.5(400.0)	600.0(500.0)	857.1(666.7)	°/sec		
		76.9(66.7)	100.0(83.3)	142.9(111.1)	rpm		
11	Default Travel Angle	CW 60° (920μs)				-	
		CCW 60° (2120μs)					
12	Max Travel Angle	CW 90° (920μs)				Programing tool (CIU-2 or CIU-3,S-Link) required.	
		CCW 90° (2120μs)					
13	BackLash*	≤ 0.5°				-	
14	Operating Temperature Range	-30~+70°C (-22~158°F)				-	
15	Storage Temperature Range	-40~+80°C (-40~176°F)				-	
16	IP Rating	IP 64				-	
17	Outer Dimension	1.59 x 0.83 x 1.51 inch (40.5 x 21.0 x 38.4mm)				-	
18	Weight	3.53oz (100g)				With Horn and screw	
19	Case Material	Upper : AL / Middle : AL / Bottom : AL				-	
20	Gear Set Material	1st,2nd,3rd,4th(Final) : Metal				-	
21	Position Sensor	Potentiometer (Contact Type)				-	
22	Motor Type	Brushless DC Motor				-	
23	Cable	Shielded Cable				Cable Length : 15.75 inch (400mm)	
24	Connector	Manufacture	Tyco Electronics				
		Type	TE794617-6				
		Mating	TE794616-6 etc.				
		Pin Assignment	1	White	S.BUS / PWM		
			2	Red	Vcc		
			3	Black	GND		
			4	Yellow	Position Feedback+		
			5	Green	Position Feedback-		
			6	Shield	Case Shield Line		
25	MTTF	260h				Test Condition at 14.8V / Load : 20% of Max. Torque / 0.5Hz sweep (±60°)	
26	Vibration Resistance *	Operating time ≥ 100 cycle (at 14.8V)				Test Condition	
						Frequency range	10 to 500Hz
						Acceleration	10G (100m/s ²)
						Sweep rate	1 oct / min
						Vibration axis	X, Y, Z

* Initial Performance Data at 23±5°C

All Specifications are subject to change without prior notice.

Caution

This product SHOULD NOT be used for the devices that is directly related to human life.

Outer Dimension

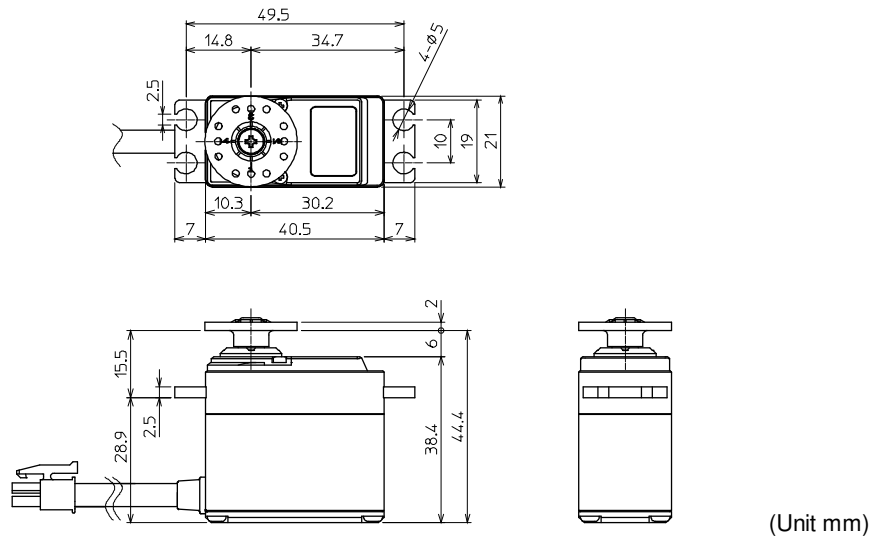

Position Feedback

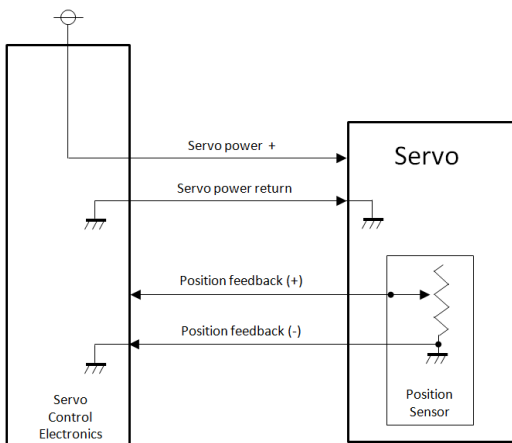

The position feedback voltage is expressed by the following formula.

$$\text{The position feedback voltage [V]} = 1.53 - \text{Actual angle [}^\circ\text{]} \times 0.012$$

Please use this formula as a reference.

In actual use, it is recommended to actually measured the relationship between angle and voltage.

BLA1HH41 PositionFeedback voltage level

