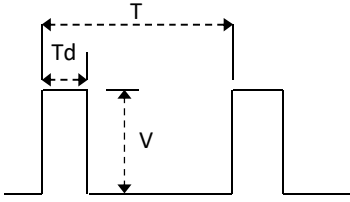
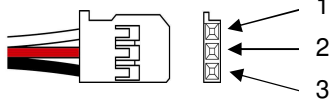
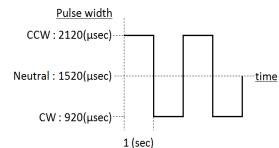

AD20-05H-A01 Technical Specification

Item		Specification				Remark	
1	Communication Interface	PWM				Signal Voltage:V	HIGH : min. 2.0V max. Vcc
							LOW : min. 0.0V max. 0.45V
						Frame Rate:T	3.0~30ms (Default 14.25ms)
						CW/Center/CCW:Td	920/1520/2120μs (Resolution recommends less than 1μs.)
							
		S.BUS				Futaba Serial Protocol (Please ask us for more information.)	
2	Rated Voltage	DC 4.8~DC 6.0V				-	
3	Operating Voltage	DC 4.0~DC 6.0V				-	
4	Standby Current	≤ 20mA				at 4.8~6.0V	
5	Starting Current*	0.7A				at 6.0V	
6	Consumption Current*	LL	Me	UL	unit	at 6.0V , No-Load	
		50	100	150	mA	LL : Low Limit Me : Medium Value UL : Upper Limit	
7	Max. Torque*	LL	Me	UL	unit	at 6.0V	
		3.1	4.1	5.1	kgf-cm		
		0.3	0.4	0.5	N-m		
		43.1	56.9	70.8	ozf-in		
8	Rated Torque*	1.2			kgf-cm	at 6.0V	
		0.12			N-m	30% of Max. Torque	
		17.1			ozf-in		
9	No Load Speed*	LL	Me	UL	unit	at 6.0V	
		0.14	0.19	0.25	s/60°		
		240.0	315.8	428.6	°/s		
		40.0	52.6	71.4	rpm		
10	Default Travel Angle	CW 60° (920us) CCW 60° (2120us)				-	
11	Max Travel Angle	CW 90° (920us) CCW 90° (2120us)				Programing tool (CIU-2 or CIU-3,S-Link) required.	
12	BackLash*	≤ 0.7°				-	
13	Operating Temperature Range	-20~+60°C (-4~140°F)				-	
14	Storage Temperature Range	-20~+60°C (-4~140°F)				-	
15	Outer Dimension	40.4 x 19.8 x 36.0mm (1.59 x 0.78 x 1.42 in)				-	
16	Weight	36g (1.27oz)				with Horn and set screw	
17	Case Material	Upper,Middle,Bottom : PP				-	
18	Gear Set Material	1st,2nd,3rd,4th(Final) : POM				-	
19	Cable	Non-Shielded Cable				Cable Length : 11.81 inch (300mm)	
20	Connector	Manufacture	J.A.M. Co., Ltd.				
		Type	FC25-03HG**				
		Mating	FC25-03M** etc.				
		Pin Assignment	1	White	PWM/S.BUS		
		2	Red	Vcc			
		3	Black	GND			
21	Water Resistance	IP40 equivalent				-	
22	MTTF	570h (at 6.0V)				Test Condition • Load : 30% of Max. Torque • Operating Condition : 0.5Hz sweep (±60°) • Input Pluse : PWM 	
23	Vibration Resistance *	Operating time > 100h (at 4.8V)				Test Condition	
						Frequency range	80 to 400Hz
						Sweep Rate	1.2 min / single-sweep
						Acceleration	30G (294m/s ²)
						Vibration axis	X, Y, Z

* At 23±5°C (Initial Performance Data)

** Custom connector. If necessary, Please use the extension cord sold from Futaba.

All Specifications are subject to change without prior notice.

Outer Dimension

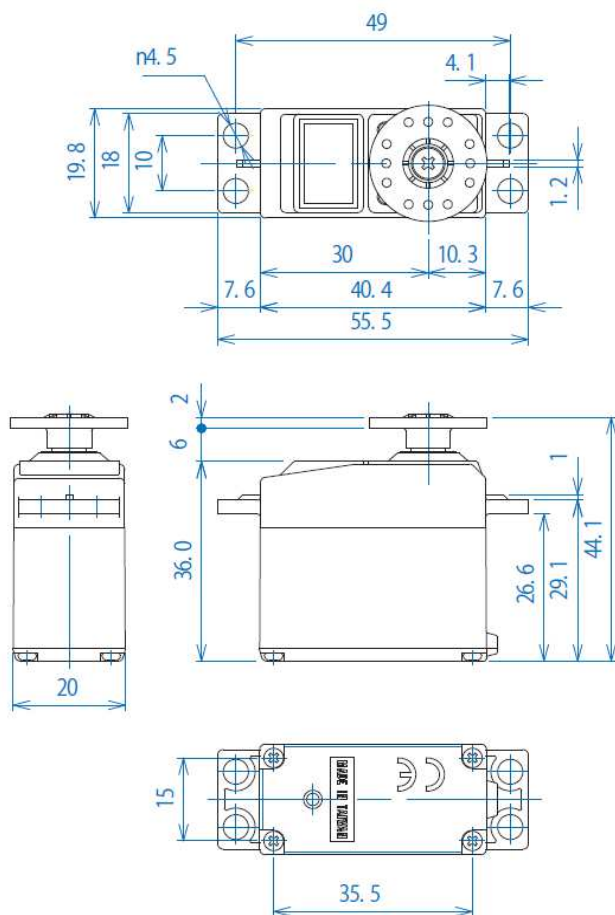

Unit(mm)

Servo Serration

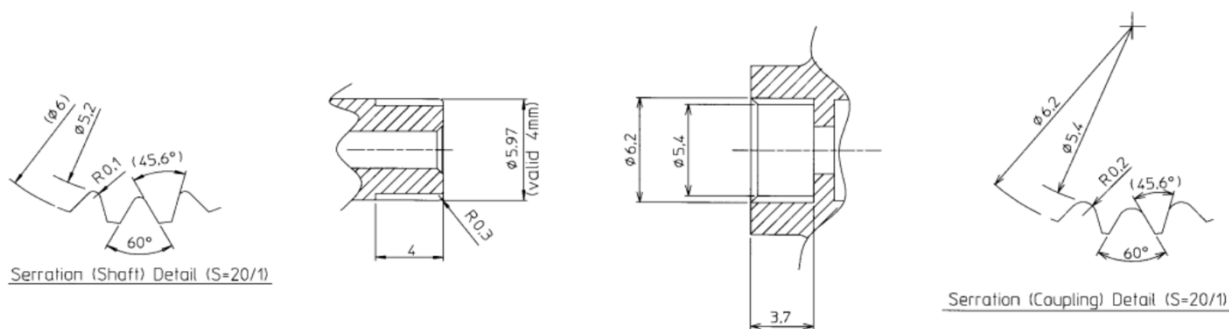

Trigonous Teeth Serration 5.2 x 6.2		
	Shaft	Coupling
Angle of Sarration	60°	60°
Number of Teeth	25	25
Shaft Addendum Circle	φ6	-----
Shaft Dedendum Circle	φ5.2	-----
Coupling Addendum Circle	-----	φ5.4
Coupling Dedendum Circle	-----	φ6.2
Over Pin Diameter	6.488 (Pin Diameter φ0.5)	5.008 (Pin Diameter φ0.4)

Unit(mm)